

## PROFICUT



## ■ BM-16 | OBARANJE IVICA NA PLOČAMA I CEVIMA

Prenosiva ručna glodalica za obaranje ivica čeličnih ploča i cevi, kao i aluminijumskih legura, mesinga ili plastike.

U zavisnosti od izabrane glave za glodanje, mašina omogućava nagib materijala minimalne debljine 1,5 mm (0,06 ") pod uglovima od 22,5°, 30°, 37,5°, 45°, 55° ili 60° i sa maksimalnim nagibom širine 16 mm (0,63 ").

Svaka glava za glodanje koristi 5 reznih pločica.

Jedna glava za glodanje za zakošeni radijus, omogućava zakošenje ivica sa poluprečnikom od 2, 3, 4 ili 5 mm uz upotrebu četverostranih indeksiranih pločica R2, R3, R4 ili R5.

Moguće je i upuštanje rupa prečnika od najmanje 40 mm (1.57").

BM-16 je opremljen stalnim podešavanjem širine kosine, zaštitom od preopterećenja i elektronskom kontrolom brzine za upotrebu na različitim materijalima.

BM - 16 je veoma efikasna mašina za pripremu materijala za zavarivanje i izradu radijusa kod čeličnih konstrukcija pre farbanja ili premazivanja.

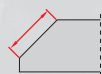

Max širina nagiba  
16 mm



Radius nagiba  
R2, R3, R4 or R5



Spoljašnji nagib cevi



Čeoni nagib



Zakrivljena ivica  
nagiba



Unutrašnji nagib cevi  
Min. ID 40 mm



Ugao nagiba  
22.5°, 30°, 37.5°,  
45°, 55° or 60°



Upuštanje rupa  
Min. ID 40 mm

## BM-16 TEHNIČKI PODACI

Napon	1~ 110-120 V, 50-60 Hz 1~ 220-240 V, 50-60 Hz
Motor	2200 W
Brzina vretena (bez opterećenja)	1800–5850 o/min
Maximum širina nagiba	b=16 mm (0.63", Sl. 2)
Ugao nagiba (u zavisnosti od glave glodalca)	$\beta = 22.5^\circ, 30^\circ, 37.5^\circ, 45^\circ, 55^\circ, 60^\circ$ (Sl. 2)
Min prečnik upuštanja rupa	ca 40 mm (1.57")
Zaobljavanje ivica	R2, R3, R4, R5 (Sl. 1)
Dimenzije (D x Š x V)	585 mm (23.0") x 156 mm (6.1") x 238 mm (9.4")
Težina (bez glave za glodanje)	10 kg (22 lbs)
Šifra proizvoda 220-240 V, 50-60 Hz	UKS-0509-10-20-00-0
Šifra proizvoda 110-120 V, 50-60 Hz	UKS-0509-10-10-00-0



Obaranje ivica na ploči



Obaranje ivica sa radijusom

### Osnovni set

- BM-16 glodalica bez dodatka (pogledajte listu ispod)
- Metalna kutija
- 32 mm ravan ključ
- Inbus ključ s=5
- Inbus ključ s=14
- Uputstvo za korišćenje (Engleski)

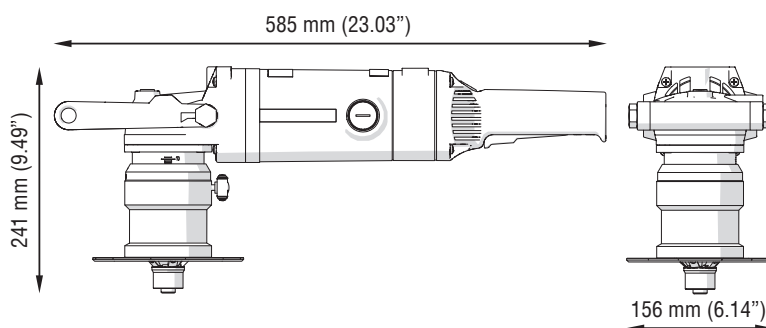

### Dodaci za glodalicu:

- GLW-000011 - Glava za zaobljavanje ivica
- PLY-000360 - Rezne pločice R2 (4 kom obavezno)
- PLY-000159 - Rezne pločice R3 (4 kom obavezno)
- PLY-000160 - Rezne pločice R4 (4 kom obavezno)
- PLY-000161 - Rezne pločice R5 (4 kom obavezno)
- PLY-000391 - Rezne pločice za čelik (4 kom obavezan – nagib do 7 mm)
- PLY-000423 - Rezne pločice za aluminijum

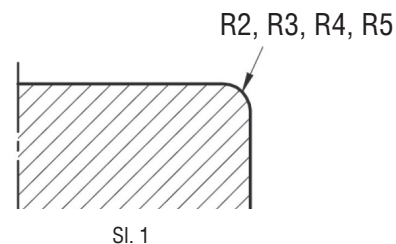

(4 kom obavezno – nagib do 7 mm)



Rezne pločice R2

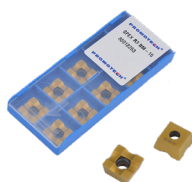

Rezne pločice R3

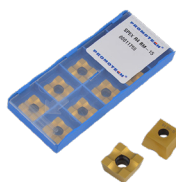

Rezne pločice R4



Rezne pločice R5

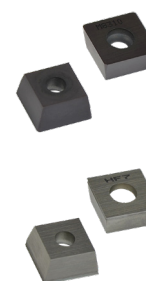

Rezne pločice za čelik

Rezne pločice za aluminijum



### Pozicioner radijusa za BM-16 i BM-7

Koristan uređaj za jednostavno i precizno podešavanje radijusa R2, R3, R4 i R5. Šifra proizvoda: UST-0509-16-00-00-0

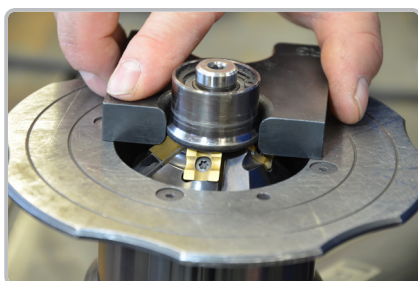

- GLW-000010 - Glava za glodanje 22.5°
- GLW-000005 - Glava za glodanje 30°
- GLW-000009 - Glava za glodanje 37.5°
- GLW-000006 - Glava za glodanje 45°
- GLW-000008 - Glava za glodanje 55°
- GLW-000007 - Glava za glodanje 60°
- PLY-000395 - Dodatak za rezanje čelika (5 kom obavezan)
- PLY-000195 - Dodatak za rezanje aluminijuma (5 kom obavezan)

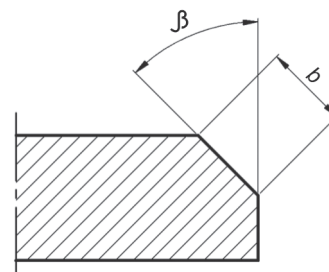

Sl. 2



Glava za glodanje 22.5°



Glava za glodanje 30°



Glava za glodanje 37.5°

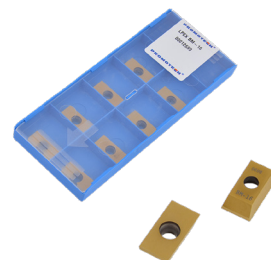

Rezne pločice za čelik



Glava za glodanje 45°



Glava za glodanje 55°



Glava za glodanje 45°

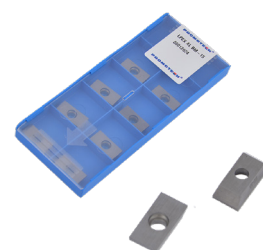

Rezne pločice za aluminijum

## ■ Spare and consumable parts:

- SRB-000289 - Dodatni šraf (radius)
- SRB-000290 - Dodatni šraf
- RLK-0509-04-00-00-0 - Vodeći valjak
- SMR-000005 - Mast za šrafove (5 g)
- SCZ-000030 - Četkica za motor 230 V
- SCZ-000031 - Četkica za motor 115 V
- NKL-0509-05-00-00-0 - Nalepnica protiv ogrebotina (namenjeno za aluminijumske nagibe)



Dodatni šraf (radius)



Dodatni šraf



Vodeći valjak



## ■ Dodatak za cevi za BM-16

Omogućava spoljašnje obaranje ivice cevi prečnika najmanje 150 mm (5.9 ") i unutrašnjeg nagiba cevi prečnika najmanje 110 mm (4.3 "). Šifra proizvoda: PRV-0509-07-00-00-0

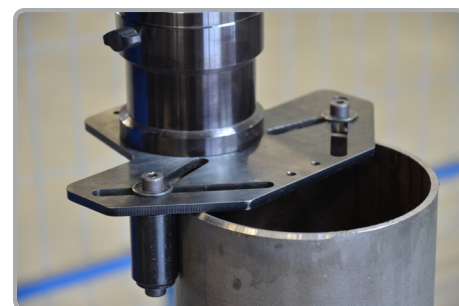

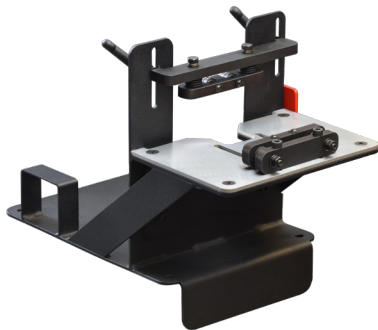

## ■ Pribor za radni sto za BM-16

Praktičan dodatak za obradu manjih radnih komada sa poprečnim presekom od najmanje 15 × 25 mm (0.6 × 1") i dužine od najmanje 400 mm (16").

Širina radnog komada može biti do 100 mm (4") i visina do 65 mm (2,5"). Maksimalna širina nagiba je 14 mm (0,55").

Šifra proizvoda: ZBD-0509-12-00-00-0

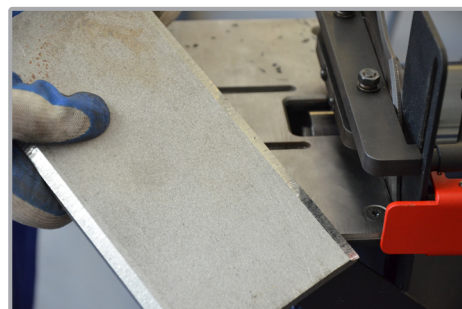
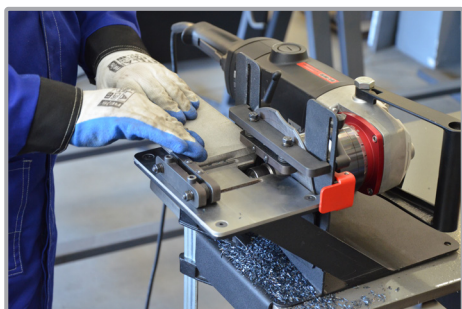

## ■ HD-CUT ekološki proizvod za hlađenje i podmazivanje

Nekorozivna sa odličnom zaštitom od rđe, biorazgradiva rashladna tečnost nudi vrhunska rashladna svojstva i omogućava duži vek trajanja alata i završnu obradu.

HD-CUT OIL 1 - za urezivanje navoja, bušenje i mašinsku obradu

Šifre proizvoda:

OLJ-0505-09-00-00-0 (0.5 kg)

OLJ-0505-10-00-00-0 (1.0 kg)

OLJ-0505-11-00-00-0 (5.0 kg)



HD-CUT BIO - koncentrat mikroemulzije za razne obrade

Šifra proizvoda:

CHL-0440-42-00-00-0



HD-CLEAN SPRAY višenamenski industrijski odmašćivač

Šifra proizvoda:

ZMY-0440-40-00-00-0



HD-CUT Spray - za urezivanje navoja, bušenje i mašinsku obradu

Šifra proizvoda:

PRE-0440-41-00-00-0



Obaranje ivica aluminijuma

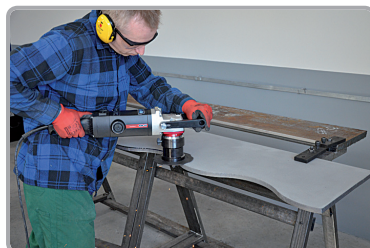

Obaranje zakrivljenih ivica



Obaranje ivica na cevima



Upuštanje rupa



## PROFICUT DOO

Industrijska zona bb, 21470 Bački Petrovac, Srbija  
sedište: Ruda Hrubika 6, Bački Petrovac, Srbija  
tel. +381 21 781 425 fax +381 21 782 207  
prodaja@proficut.rs www.proficut.rs www.shop.proficut.rs

Beleške: